



## r e s p o n s i v e

### **rugged**

#### **Work efficiently**

The TMF-55 is ready to perform in any terrain, under any condition. The hydrostatic drive, coupled to a throttle pedal, provides quick vehicle movement and precise inching control. Operators safely control the exact position of every load.

The platform allows easy access to the centre mounted seat from both sides of the unit. All instruments and controls are within operator reach thereby reducing driver fatigue.

The TMF-55 easily mounts on your truck or trailer providing quick and efficient material handling.

## **TMF-55** **truck mounted forklift**

# **SELICK**

# TMF-55 truck mounted forklift

Lift capacity of 5,500 @ 24" load centre

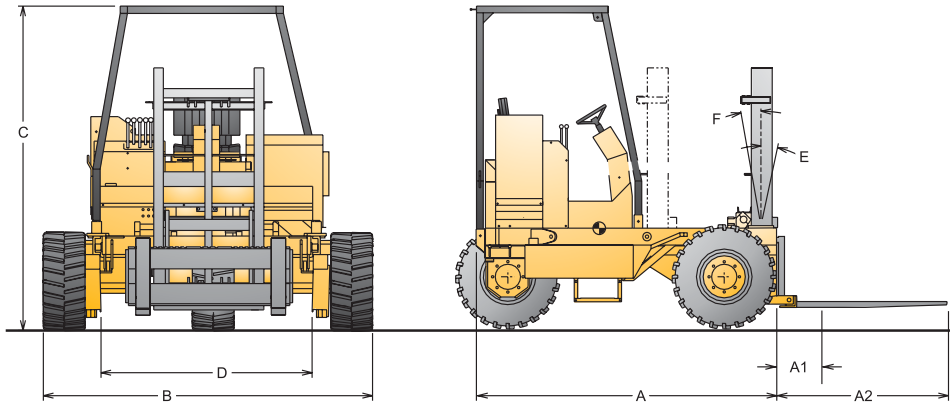

Model	Ref	TMF-55
Lift capacity @ 24 inch load centre		5 500 lbs/2 500 kg
Base operating weight		6 000 lbs/2 720 kg
Overall length (without forks)	A	89"/2 261 mm
Overall mast retracted (with 42" forks)	A1	14"/356 mm
Overall mast retracted (with 48" forks)	A1	20"/508 mm
Overall mast extended (with 42" forks)	A2	45"/1 143 mm
Overall mast extended (with 48" forks)	A2	52"/1 295 mm
Overall width	B	100"/2 540 mm
Height to top of overhead guard	C	96"/2 438 mm
Frame opening	D	58"/1 470 mm
Outside turning radius		85"/2 159 mm
Turn circle radius		106"/2 692 mm
Mast sideshift		5.25"/133 mm
Mast underclearance		12"/305 mm
Mast tilt - forward	E	12°
Mast tilt - rearward	F	10°
Gradeability		30%
Tire size type & size (pneumatic)		31 - 15.5 - 15
Engine manufacturer & model		Deutz (Model F3L2011)
Engine type		Diesel naturally-aspirated
Cylinders		3
Engine output (gross power)		45 hp
Transmission type		Hydrostatic

Because of our constant dedication to product improvement, all specifications are subject to change without notice.

— All Sellick forklifts meet or exceed all ANSI B56.6 safety standards. —



**Sellick Equipment Limited**

P.O. Box 1000/358 Erie Street North • Harrow, Ontario, Canada • N0R 1G0  
519-738-2255 • sellick@mnsi.net

## Standard specifications

The TMF-55 truck mounted forklift features a centrally-positioned seat and automotive-style controls with inching capabilities for increased operator productivity. The hydrostatically-driven two-wheel drive (with on-demand three-wheel drive) TMF-55 can power through uneven ground conditions especially with the use of traction lock feature.

## Engine

Deutz low noise, low emission, three-cylinder, 45 hp, diesel engine.

## Transmission

Hydrostatic transmission.

## Steering

Hydrostatic steering.

## Instruments

Full instrument package includes warning indicator lights & gauges, horn & backup alarm.

## Standard equipment

- Fully adjustable seat with retractable seatbelt
- Automotive-style controls
- Stabilizers
- 5-spool hydraulic valve
- Battery box
- Air cleaner
- Inching control
- Two- or three-wheel drive on demand
- Two front & 1 rear worklight
- Clearance lights for transport
- Ergonomically-designed centre-mount operator station
- Traction control for extra power over rough spots
- Large 31x15.5-15 tires for excellent traction

## Optional equipment

- Mast heights available: 72"/183 cm, 96"/244 cm, 120"/305 cm, 144"/366 cm
- Standard pad mount
- Under-ride protection bumper
- Beacon light - strobe
- Frame-mounted load supports

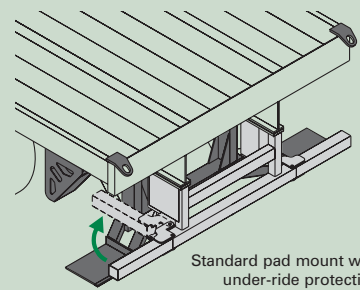

Standard pad mount with under-ride protection bumper shown.